

SINE WAVE GENERATION USING NUMERICALLY CONTROLLED OSCILLATOR MODULE

PRIYANKA P. CHOPDA¹, KAVITA S. TATED² & JAYANT J. CHOPADEV³

¹PG Student, Department of E & TC, SNJB's KBJ, Chandwad, Nashik, India

²Professor, Department of E & TC, SNJB's KBJ, Chandwad, Nashik, India

³Principal, Professor, Department of E & TC, SNJB's KBJ, Chandwad, Nashik, India

ABSTRACT

A Numerically Controlled Oscillator (NCO) is a digital signal generator which creates a synchronous i.e. clocked, discrete-time, discrete-valued representation of a waveform, usually sinusoidal [1]. NCOs are often used in combination with a digital to analog converter (DAC) at the output to create a direct digital synthesizer (DDS). NCOs are used in many communications systems such as software radio systems & digital up/down converters used in 3G wireless, RADAR systems, digital PLLs, drivers for optical or acoustic transmissions & multilevel FSK/PSK modulators/ demodulators[2]. The NCO Design is first simulated & optimized on the software tool Xilinx 10.1 & then VHDL for hardware Realization. The designs are tested on Xilinx Spartan2 FPGA Development Platform. This paper presents the implementation of Sine Wave Generation using NCO module which improves the performance, reduces the power & area requirement

KEYWORDS: Numerically Controlled Oscillator, FPGA, DDS

INTRODUCTION

A key requirement in most applications is the ability to generate & control waveforms at various frequencies. Advantages of Numerically Controlled Oscillators over other types of oscillators in terms of agility, accuracy, stability & reliability [2]. The Direct Digital Synthesis (DDS) technique is become popular & gets accepted by industrial community to achieve programmable analog outputs with accuracy & high resolution. NCO is new technology of Frequency synthesis which is developed using 3rd generation of Frequency synthesis technology. The technique of NCO is become popular as a method of sinusoidal signal generator & signals in digital systems modulator [3]. NCO is an important component in many Digital Communication Systems such as Digital Radios & Modems, Software Defined Radios, Digital Down/Up converters for Cellular & PCS base stations etc.

In this paper NCO module is used for Sine Wave Generation based on DDS technique. The NCO module operates on the principle of DDS by repeatedly adding a fixed value to an accumulator. The NCO module can operate in two modes: 1) fixed duty cycle PWM mode 2) frequency controlled pulse mode.

OVERVIEW OF NCO

Architecture of NCO

Figure 1 shows the block diagram of a NCO system. The block diagram of NCO consists of N-bit frequency register, N-bit phase register, sine lookup table, DAC, filter. NCO is constructed by a ROM with samples of sine wave which stored in sine look up table [4]. The NCO produces sinusoidal signals at a given frequency setting word (FSW)

which determines the phase step. The combination N-bit register, N-bit phase register & Sine Lookup Table is known as Phase Accumulator which is used to calculate the successive addresses of sine lookup table & generates a digital sine wave output. The digital part of the NCO consists of the phase accumulator and the LUT. Once set, this digital word determines the sine wave frequency to be produced. The phase accumulator output then continuously produces proper binary words indicating the instantaneous phase to the table look-up function.

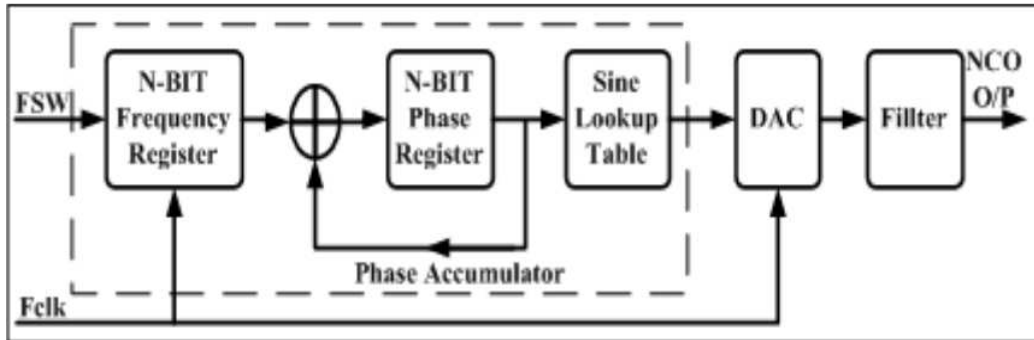

Figure 1: Block Diagram of NCO System

The NCO translates the resulting phase to a sinusoidal waveform via the look-up table, and converts the digital representation of the sine-wave to Analog form using a Digital-to-Analog converter followed by a low pass filter (LPF).

The frequency of the output signal for signal N-bit system is determined by following equation

$$F_{out} = \frac{K \times F_{clk}}{2^N}$$

Where K is the FSW,

N is the number of bits that the phase accumulator can handle

Fclk is system clock.

NCO Specification

Table 1: NCO Specifications

Sr.No	Specifications	Parameter Value
1.	Phase Resolution (Bits)	9
2.	Spur Level (dB)	54.18
3.	Frequency Resolution (Bits)	24
4.	Output Signal	SINE & COSINE
5.	Output Data Width	9 BITS

Internal Block Diagram of NCO Module

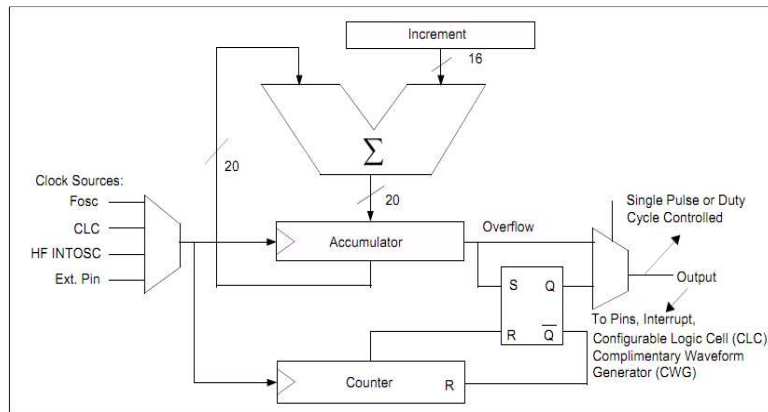

Figure 2: Internal Block Diagram of NCO Module

The NCO module operates on the principle of DDS by repeatedly adding a fixed value to an accumulator. The accumulator is 20 bits in length and additions occur at the input clock rate, which can be a maximum of about 16MHz. The accumulator will overflow with a carry bit set periodically, and this will produce a transition in the output of the NCO module. The NCO module can operate in two modes: fixed duty cycle PWM and frequency controlled Pulse mode. With such an arrangement, the response will be very linear across a wide range of frequencies, ranging from 0 kHz up to 500 kHz using a clock of 16MHz. The frequency resolution that can be obtained is precise and is in steps of 15 Hz across this entire frequency range. The linear frequency control and the increased frequency resolution are the key distinguishing factors when compared to the traditional PWM-based frequency control. The NCO module generates precisely controllable output frequencies using the DDS technique. The DDS technique essentially provides a clock with carefully controlled jitter on it. Therefore, it is necessary that the signal be aggregated on the frequency domain.

DIRECT DIGITAL SYNTHESIS (DDS)

Direct Digital Synthesis is a technique of generating an analog waveform, generally of sinusoidal wave shape from a time varying signal in its digital form & DAC. Direct Digital Synthesis (DDS) is a method of producing an analog waveform usually a sine wave by generating a time varying signal in digital form & then performing a digital to analog conversion. Because operations within a DDS device are primarily digital, it can offer fast switching between output frequencies, fine frequency resolution, and operation over a broad spectrum of frequencies. With advances in design and process technology, today's DDS devices are very compact and draw little power.

Figure 3 shows the internal components of Direct Digital Synthesizer. Its main components are Phase accumulator it means that phase to amplitude conversion & DAC.

A DDS output produces a sine wave at a given frequency. The frequency depends on two variables are the Reference Clock Frequency and the binary number programmed into the frequency register (tuning word).

The binary number in the frequency register provides main input to the phase accumulator & phase accumulator then calculate the phase angle i.e. the address for look up table which gives the digital value of amplitude & then to then to the DAC. DAC converts digital value into analog voltage or current. For fixed frequency sine wave constant value is added to the phase accumulator. If phase increment is large the phase accumulator will step quickly & generate high frequency sine wave. If phase increment is small the phase accumulator will take many more steps & generate lower

frequency sine wave.

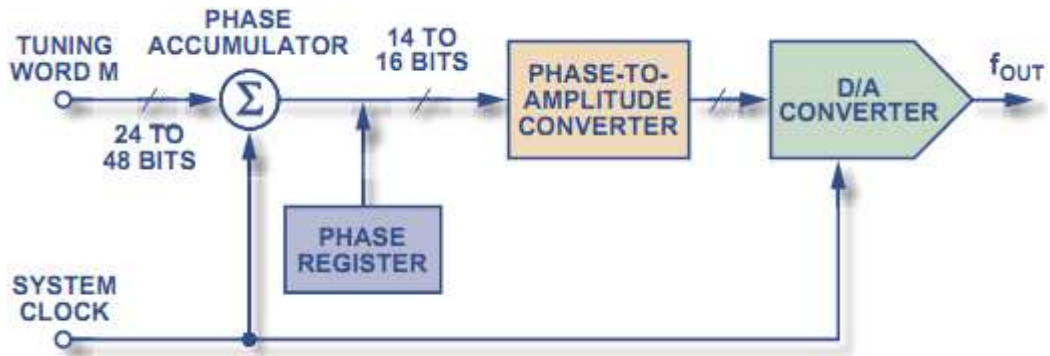

Figure 3: Internal Circuit of Direct Digital Synthesizer

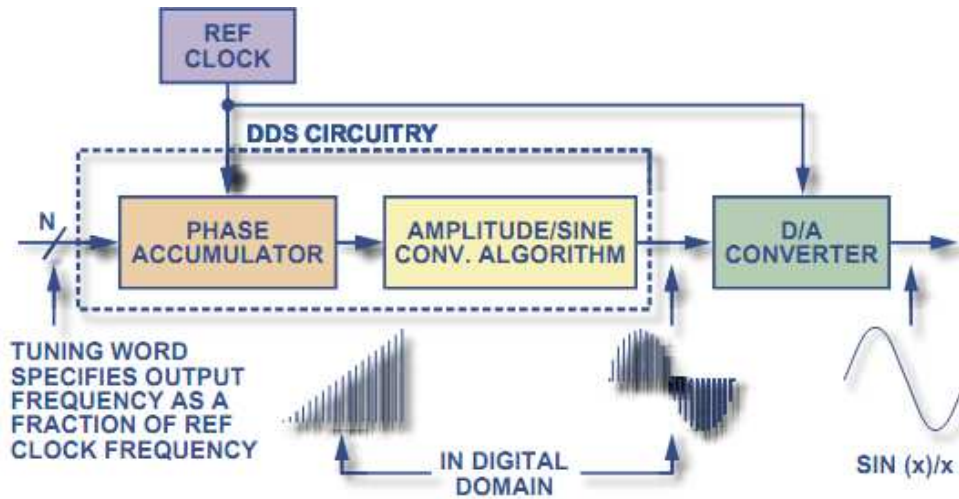

Figure 4: Signal Flow through the DDS Architecture

Figure 4 Gives the Detail Signal Flow through DDS Architecture & Analog Sinusoidal Waveform.

NCO OUTPUT

$$F_{nco} = \frac{F_{osc}}{ACCUMULATOR} \times \text{Increment Value}$$

Where F_{nco} = Frequency of output of NCO module

F_{osc} = Oscillator clock frequency (16 MHz)

Accumulator = 20 bit summing register that overflows to create an output transition

Increment Value = Value loaded to change F_{nco}

F_{nco} is directly proportional to the increment value and accumulator overflow value is always fixed to $2^{20}=1048576$. Therefore, any change in the increment value will yield a very linear variation in the output frequency of the NCO i.e F_{nco} . Therefore, a better frequency resolution over a wide frequency range can be obtained using the NCO for waveform generation.

PRINCIPLE OF SINE WAVE GENERATION USING NCO MODULE

The output of NCO module will be a square wave at the configured frequency. A square wave has many frequency components with the main frequency being the center frequency, as per the NCO configuration. A square wave could be generated by adding a series of pure tones (sine waves) with appropriate amplitude and phase as per the Fourier Transforms. Fourier theorem assumes that the user add sine waves of infinite duration. Therefore, a square wave is essentially composed of Fundamental frequency $-1/3$ of third harmonic tone $+1/5$ of fifth harmonic tone $-1/7$ of seventh harmonic tone, and so on. The square wave output from the NCO can be passed through a Band Pass Filter with a high Q factor to generate a sine wave at the desired frequency.

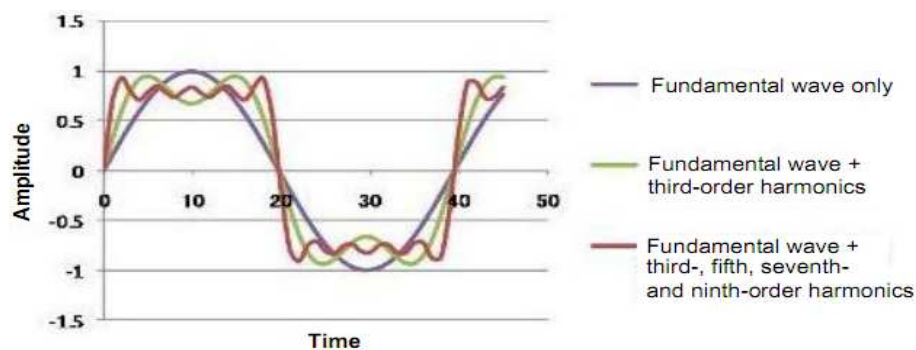

Figure 5: Frequency Wave Components in Square

APPLICATIONS OF SINE WAVE GENERATOR

- Calibration of sound equipment or speakers
- Detection of frequency components in a signal
- Generate test tones for radio audio level alignment
- Radio tuning circuitry
- Reference tone generation to tune and adjust musical instruments
- Acoustic equalization and testing
- Creation of harmonics for generating multiple sound frequencies
- Sound card quality control
- White noise generator
- Hearing test equipment

CONCLUSIONS

However, there are plenty of applications of a sine wave, because it forms the basic function for most of the electrical and electronic systems. Using the Numerically Controlled Oscillator (NCO) module to generate a sine wave at any desired frequency and its advantages over the conventional Pulse-Width Modulation (PWM) approach have also been covered. The use of the NCO is not limited to the generation of a sine wave. By using a proper filter with an appropriate

cutoff frequency, any desired wave shape can be rendered to the resultant output.

REFERENCES

1. Jane Radatz, The IEEE Standard Dictionary Of Electrical & Electronics Terms, IEEE Standards office, New York, NY, 1997.
2. Numerically Controlled Oscillator, Lattice Semiconductor Corporation, 2009.
3. M.L. Welborn, "Direct Waveform Synthesis for software Radios," IEEE Wireless Communications & Networking Conference WCNC.1999, vol 1, pp.211-215, September 1999.
4. P.O. Bishop, Neurophysiology of binocular vision in J. Houseman [Ed], Handbook of physiology, 4 (New York; Springer- Verlog, 1970) 342-36

